

About Hawking radiation

Current insights on Hawking radiation

On Wikipedia the following can be found about Hawking radiation:

Hawking radiation is blackbody radiation that is predicted to be released by black holes, due to quantum effects near the event horizon. It is named after the physicist Stephen Hawking, who provided a theoretical argument for its existence in 1974,[1] and sometimes also after Jacob Bekenstein, who predicted that black holes should have a finite, non-zero temperature and entropy [2].

Hawking's work followed his visit to Moscow in 1973 where the Soviet scientists Yakov Zeldovich and Alexei Starobinsky showed him that, according to the quantum mechanical uncertainty principle, rotating black holes should create and emit particles.[3] Hawking radiation reduces the mass and energy of black holes and is therefore also known as black hole evaporation. Because of this, black holes that do not gain mass through other means are expected to shrink and ultimately vanish. Micro black holes are predicted to be larger net emitters of radiation than larger black holes and should shrink and dissipate faster.

In June 2008, NASA launched the Fermi space telescope, which is searching for the terminal gamma-ray flashes expected from evaporating primordial black holes.[4][5][6]

https://en.wikipedia.org/wiki/Hawking_radiation

NASA designed on 9 august 2007 [7] the mission with a five-year lifetime, with a goal of ten years of operations. One of the key scientific objectives of the Fermi mission is:

“Search for evaporating primordial micro black holes (MBH) from their presumed gamma burst signatures [Hawking Radiation component].”

https://en.wikipedia.org/wiki/Fermi_Gamma-ray_Space_Telescope

While Hawking radiation is sometimes questioned,[8] Leonard Susskind summarizes an expert perspective in his recent book:[9] "Every so often, a physics paper will appear claiming that black holes don't evaporate. Such papers quickly disappear into the infinite junk heap of fringe ideas".

https://en.wikipedia.org/wiki/Micro_black_hole

Although Hawking radiation is not seriously questioned a steady evidence is not found by NASA or others.

Consideration 1

In our article we suggest that a photon consist of two db-particle that are moving in each other curvature (fig. 4 in our article) and traveling through space/time (www.dbphysics.org). We suggest that a photon is influenced on her track by curvatures caused by other particles. Hereby the photon will be brought “out of balance”.

Under the influence of extreme curvatures, the photon will undergo a wavelength shift. We call this “the aging of the photon.” Because both db-particles experience an enormous curvature from each another (within the photon), this is a very slow process for the observer. But during a trip through space/time lasting many light-years (e.g. 10 billion light-years) the effect can be seen by the observer (redshift).

Under the influence of extreme curvatures in space, the “aging” of a photon can accelerate greatly. This is observable near black holes. The closer the track of a photon to a black hole, the greater the

aging. In fact, close to an event horizon of a black hole, the aging (gravitational redshift) can become infinite. In this process the photon will undergo spaghettification [10] caused by extreme tidal forces. At a certain point the photon can no longer escape and is being captured by the black hole.

One can imagine that in the process of spaghettification there is a situation that the absorption is not yet an accomplished fact. In the “slow” process (for the observer) the 1-db particles within the photon are being separated as a wire. They are still entangled but the entanglement gets weaker. It is thinkable that at this moment one of the particles is being captured and the other escapes from the event horizon. This will give a 1-db radiation which can not be seen with the traditional methods (under Heisenberg). This suggested radiation is not caused by vaporisation of a black hole but is due to the devastating tidal forces of the black hole.

Sonic black hole in the laboratory

Jeff Steinhauer (Technion-Israel of Technology) claims to have created a sonic black hole to observe Hawking radiation and its quantum weirdness, all within the safe confines of his laboratory.

To recreate the effects of an event horizon, Steinhauer used a laser to trap atoms in place on one side of the condensate and a second laser to create a step potential on the other side. The step potential acts like a waterfall, once atoms go over the limit they quickly speed up, travelling faster than the speed of sound and are considered as being inside the event horizon. Atoms that don't make it over the step potential move at subsonic speeds, and are interpreted as being outside of the event horizon. The speed of flow in the superfluid mimics the gravitational pull of black holes.

Photons -particles of vibrational energy- escape (according to current insights) analogous to Hawking radiation.

Steinhauer's results are published in Nature Physics, and show that (according to current insights) Hawking radiation is entangled. He measured the correlation function - a measure of how the properties of two particles in different positions are related - and found a high correlation for high-energy photons but low correlation for low-energy photons.

Photons equidistant from the event horizon were correlated and had equal and opposite energy, Steinhauer explained (this is analogous to Positron Emission Tomography, red.).

Particles are –according tot Steinhauer- created out of nothing. According to Steinhauer it doesn't violate the principle of physics, however, as the total energy balances out to zero.

“The entanglement verifies the quantum nature of the Hawking radiation,” the Steinhauer paper said. The next step, Steinhauer hopes, is to use artificial black holes to tackle larger problems like the information paradox or maybe even quantum gravity.

https://www.theregister.co.uk/2016/08/16/quantum_hawking_radiation_has_been_created_in_a_lab_claims_physicst/

Consideration 2

In his experiment Steinhauer traps atoms and brings these atoms in an agitated state. Among these atoms there are neutrons. These neutrons can undergo the following process as suggested in our article (www.dbphysics.org, fig. 8 and fig. 9):

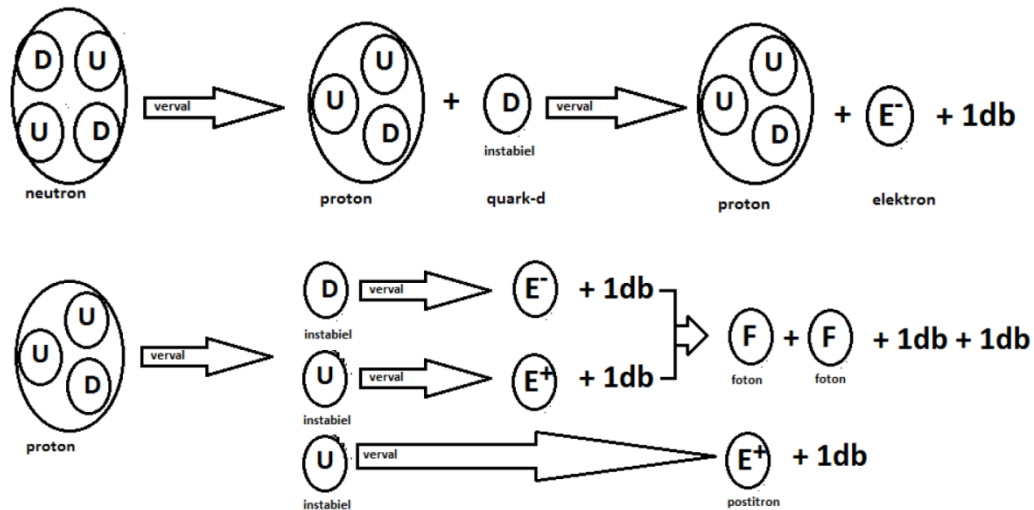

Seen from our perspective the complete decay of a neutron -through a proton- will end up in four photons [5]. There are two different pairs of photons. The pairs differ in characteristics. One pair of photons will be created instantly in the decay of a proton. This pair will be highly energized and highly entangled (for 1db we use the symbol λ). The other pair is created when the electron that is created in the first step ($n \rightarrow e^- + 1\lambda + p$) finds the positron. The positron is created in the second step ($p \rightarrow 2\lambda + 3\lambda + e^+$). This photon pair will be less energized and less entangled.

Our suggestion meets the observation of Steinhauer.

Jelle Ebel van der Schoot, Gerhard Jan Smit, 1 March 2017, Nijmegen

- [1] Rose, Charlie. "A conversation with Dr. Stephen Hawking & Lucy Hawking". charlirose.com. Arc. rom the original on March 29, 2013.
- [2] Levi Julian, Hana (3 September 2012). "'40 Years of Black Hole Thermodynamics' in Jerusalem". Arutz Sheva. Retrieved 8 Sept. 2012.
- [3] Hawking, Stephen (1988). A Brief History of Time. Bantam Books. ISBN 0-553-38016-8.
- [4] Giddings, S.; Thomas, S. (2002). "High energy colliders as black hole factories: The end of short distance physics". Physical Review D. 65 (5): 056010. arXiv:hep-ph/0106219Freely accessible. Bibcode:2002PhRvD..65e6010G. doi:10.1103/PhysRevD.65.056010.
- [5] Dimopoulos, S.; Landsberg, G. (2001). "Black Holes at the Large Hadron Collider". Physical Review Letters. 87 (16): 161602. arXiv:hep-ph/0106295Freely accessible. Bibcode:2001PhRvL..87p1602D. doi:10.1103/PhysRevLett.87.161602. PMID 11690198.
- [6] "The case for mini black holes". CERN courier. November 2004.
- [7] "The GLAST Mission: GLAST Overview, mission length". NASA. Retrieved 9 August 2007.
- [8] Helfer, A. D. (2003). "Do black holes radiate?". Reports on Progress in Physics. 66 (6): 943–1008. arXiv:gr-qc/0304042Freely accessible. Bibcode:2003RPPh...66..943H. doi:10.1088/0034-4885/66/6/202.
- [9] Susskind, L. (2008). The Black Hole War: My battle with Stephen Hawking to make the world safe for quantum mechanics. New York: Little, Brown. ISBN 978-0-316-01640-7.
- [10] [Calder, Nigel](#) (1977). *The Key to the Universe: A Report on the New Physics (1st ed.)*. Viking Press. p. 199. ISBN 978-0-67041270-9, a companion to a one-off [BBC](#) TV documentary: *The Key to the Universe*.

www.dbphysics.org